



**air master**  
ISO 9001 CERTIFIED COMPANY



# LINEAR SLOT DIFFUSERS



[www.airmasteremirates.com](http://www.airmasteremirates.com)



# INDEX

SECTION	TOPIC	PAGE
SLOT DIFFUSERS		
7.1	<b>Supply Air Linear Slot Diffuser ASLD</b>	3
7.2	<b>Return Linear Slot Diffusers ARLD</b>	4
7.3	• <b>Slot Diffuser dimensions</b>	5
7.3	• <b>Possible air deliveries</b>	5
7.4	<b>Curved Supply Linear Slot Diffusers ASLD (C)</b>	6
7.5	• <b>Optional Mitered Corners</b>	7
7.5	• <b>Flange models</b>	7
7.6	• <b>Optional profiles</b>	8
7.6	• <b>Fixing details</b>	8
7.21	• <b>Product summary and order checklist</b>	23
7.16	<b>Linear slot diffuser ASMLD</b>	18
7.19	<b>Plenum slot diffuser ASMPD</b>	21
AIR FLOW DATA		
7.7	<b>Supply linear slot diffuser - 20 mm: ASLD Tab. 7.1</b>	9
7.9	<b>Supply linear slot diffuser - 25 mm: ASLD-25 Tab. 7.2</b>	11
7.11	<b>Supply linear slot diffuser - 16 mm: ASLD-16 Tab. 7.3</b>	13
7.13	<b>Return linear slot diffusers - 20 mm: ARLD Tab. 7.4</b>	15
7.14	<b>Return linear slot diffuser - 25 mm: ARLD-25 Tab. 7.5</b>	16
7.15	<b>Return linear slot diffuser - 16 mm: ARLD-16 Tab. 7.6</b>	17
7.17	<b>Linear slot diffuser - 16 mm: ASMLD</b>	19
7.20	<b>Plenum slot diffuser - 19mm: ASMPD</b>	22

**Cover Page Photo**

Seef Mall Food Court, Bahrain.

## CONSTRUCTION:

**Frame & Blades:** High quality extruded aluminium profiles.

**Frame width:** 30 mm standard. 20 mm also available

**Damper:** Hit and miss damper.

**Slot width:** 20 mm as standard. 16 mm, 25 mm

and non standard sizes available as option.

**Number of slots available:** 1, 2, 3, 4, 5, 6, 7, 8.

**Length:** Up to 5.8 mt available in a single piece.

**Optional accessories:** Plenum box either un lined, internally insulated or externally insulated.

## Description:

- Frame and deflection blades are made of high quality extruded aluminium profiled construction with the advantages of corrosion resistance and rigidity.
- Air distribution can be changed vertically or horizontally by means of deflection blades with out changing the air flow rate. These blades can be fully adjusted from face opening.
- Air flow rate can be adjusted by fixing hit and miss damper at the rear side of the diffuser. Damper blades are adjusted from the face opening.
- Dampers are designed in a unique way that it can be used as an equalizing grid.
- Positive alignment of adjacent sections can be made by using alignment strips.
- Suitable for installation for ceiling and sills.
- Foam gasket sealed around the back of the frame to avoid air leakage.

## Standard finishes:

- Natural anodized aluminium finish.
- Powder coated colour finish as per RAL colour code.
- Flexibility of finish available.

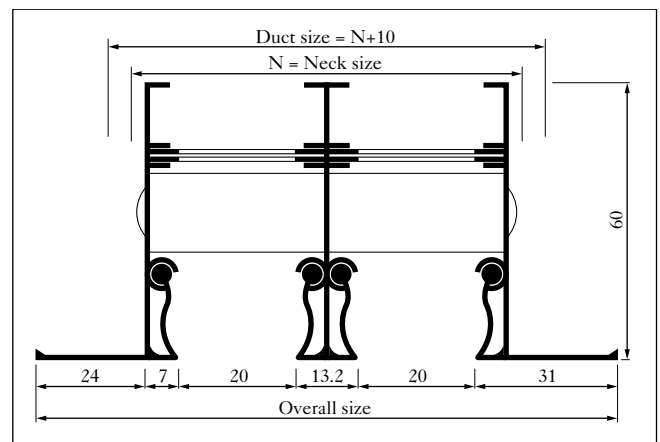
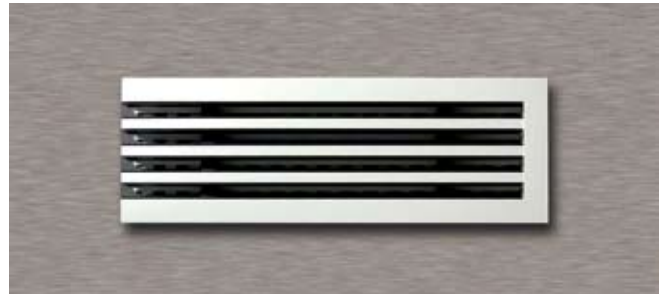

**CONSTRUCTION:**

**Frame & Blades:** High quality extruded aluminium profiles.

**Frame width:** 30 mm standard. 20 mm also available.

**Damper:** Hit and miss damper.

**Slot width:** 20 mm as standard. 16 mm, 25 mm

and non standard sizes available as option.

**Number of slots available:** 1, 2, 3, 4, 5, 6, 7, 8.

**Length:** Up to 5.8 mt available in a single piece.

**Optional accessories:** Plenum box either un lined, internally insulated or externally insulated.

**Description:**

- Frame and deflection blades are made of high quality extruded aluminium profiled construction with the advantages of corrosion resistance and rigidity.
- Positive alignment of adjacent sections can be made by using alignment strips that are provided with each diffuser.
- Structure is manufactured by mechanical assembly to ensure rigidity and straight line appearance.
- Available with out hit and miss damper as standard. Damper will be provided as option.
- Suitable for installation into ceiling and sills.

**Standard finishes:**

- Natural anodized aluminium finish.
- Powder coated colour finish as per RAL colour code.
- Flexibility of finish available.

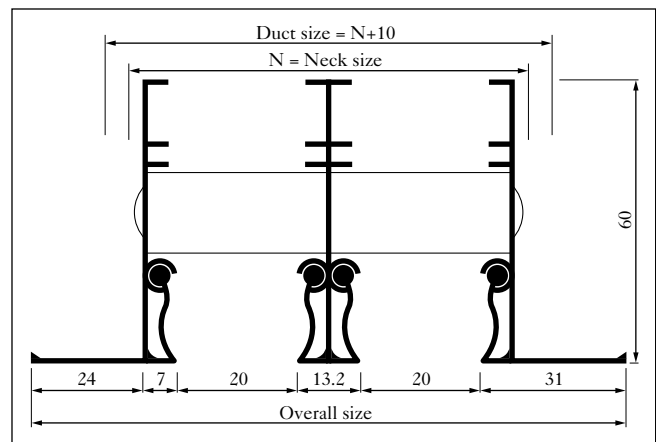
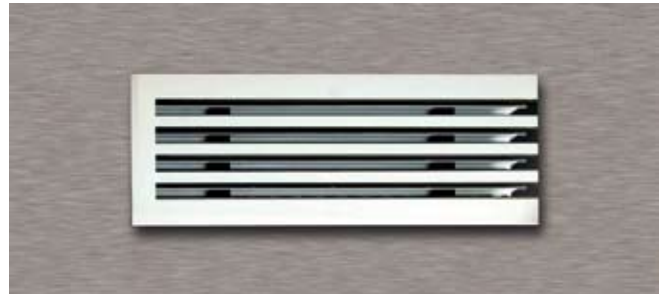

## For 30 mm flange width:

### • 16 mm slot opening

No. of slots	1	2	3	4	5	6	7	8
Neck size in mm	34	65	96	128	159	190	221	252
Duct size in mm	44	75	106	138	169	200	231	262
Overall size	80	111	142	174	205	236	267	298

### • 20 mm slot opening

No. of slots	1	2	3	4	5	6	7	8
Neck size in mm	37	71	105	140	174	208	242	276
Duct size in mm	47	81	115	150	184	218	252	286
Overall size	83	117	151	185	220	254	288	322

### • 25 mm slot opening

No. of slots	1	2	3	4	5	6	7	8
Neck size in mm	42	81	120	160	199	238	277	316
Duct size in mm	52	91	130	170	210	248	287	326
Overall size	88	127	166	205	245	284	323	362

- For 20 mm flange width, overall size must be reduced by 20 mm.
- For Curved slot diffuser, please increase the wall/ceiling slot 6 mm.

## Possible air deliveries

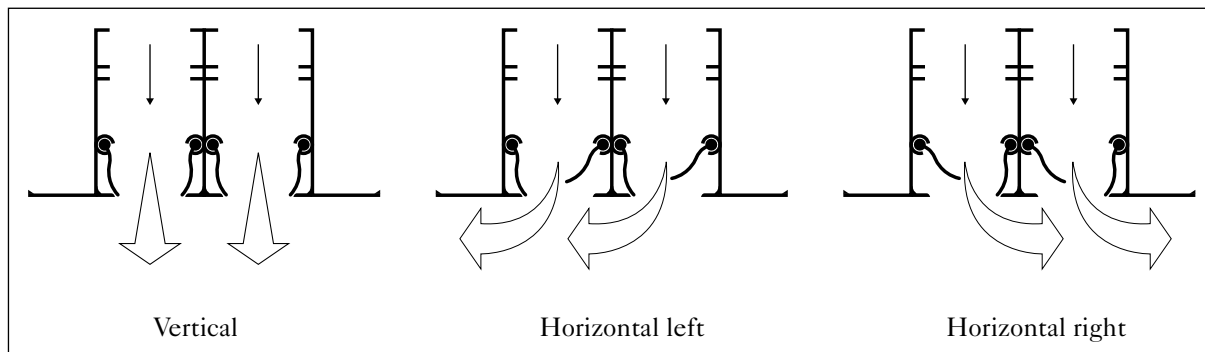

**CURVED SUPPLY AIR  
LINEAR SLOT DIFFUSER**
**air master**  
 ISO 9001 CERTIFIED COMPANY
**CONSTRUCTION:**

**Frame & Blades:** High quality extruded aluminium profiles.

**Frame width:** 30 mm standard. 20 mm also available.

**Damper:** Hit and miss damper.

**Slot width:** 20 mm as standard. 16 mm, 25mm and non standard sizes available as option.

**Number of slots available:** 1,2,3,4,5,6,7,8.

**Length:** Up to 3 mt available in a single piece.

**Description:**

- Frame and deflection blades are made of high quality extruded aluminium profiled construction with the advantages of corrosion resistance and rigidity.
- Hit and miss damper will be fixed rigidly at the rear side of the diffuser as option.
- Positive alignment of adjacent sections can be made by using alignment strips.
- Foam gasket is sealed around the back of the frame as option to avoid air leakage.
- Suitable for installation in ceiling and sills.
- Supply and return air curved linear slot diffusers are available up to a length of 3 meters with a minimum radius of curvature of 1 meter.
- Standard application on the ceiling.

**Model: ARLD(C):** Same as ASLD(C), without hit and miss damper.

**Standard finishes:**

- Natural anodized aluminium finish.
- Powder coated colour finish as per RAL colour code.
- Flexibility of finish available.

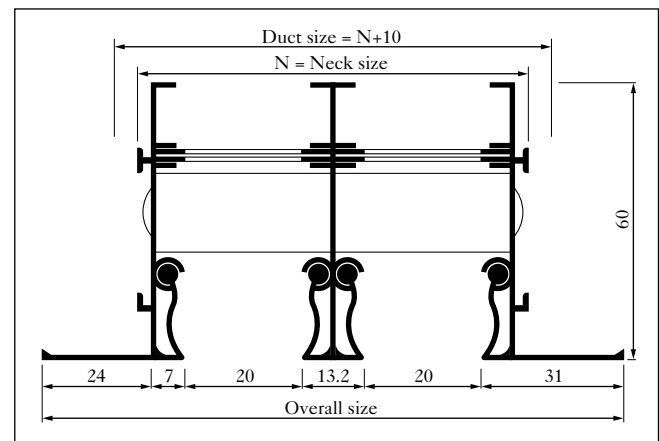

## Optional mitered corners:

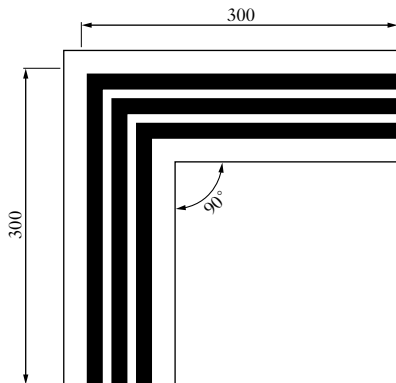

**7 a. 90° Mitered corner**

Standard 90° horizontal mitered corners available for floor, sill and ceiling applications.

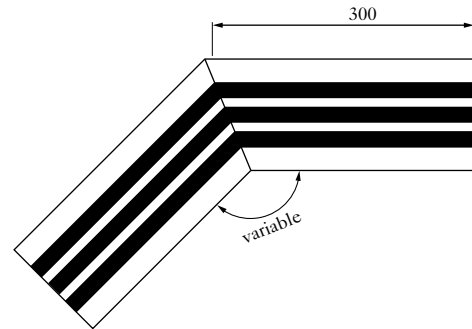

**7 b. Variable mitered corner**

Special horizontal mitered corners selection available for floor, sill and ceiling applications includes an angle greater than 90° and less than 180°.

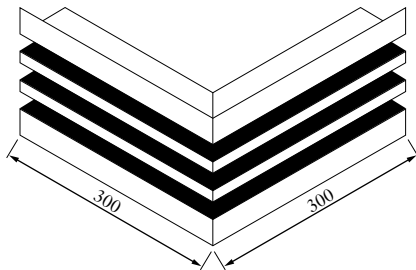

**7 c. Side wall - outside corner**

Vertical outside mitered corners are available for wall application at the junction of two outside walls with a standard angle of 90°.

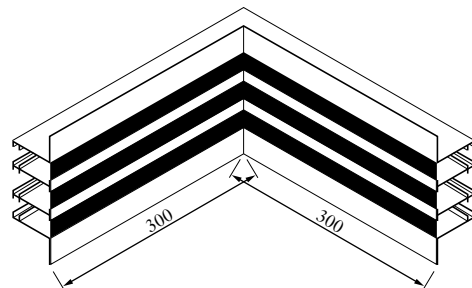

**7 d. Side wall - inside corner**

Vertical inside mitered corners are available for wall application at the junction of two inside walls with a standard angle of 90°.

## Flange models:

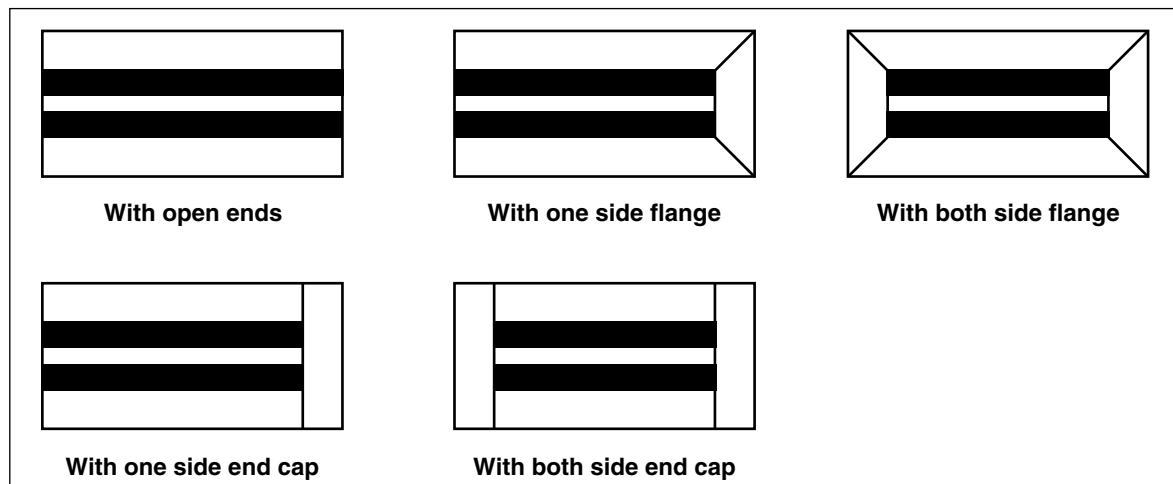

# OPTIONAL PROFILES & FIXING DETAILS



**air master**  
ISO 9001 CERTIFIED COMPANY

## Optional profiles

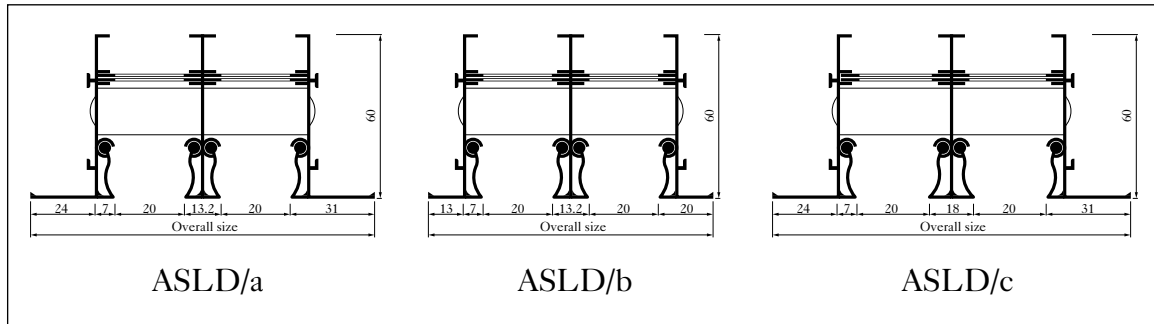

## Fixing details

### • C-Clamp fixing

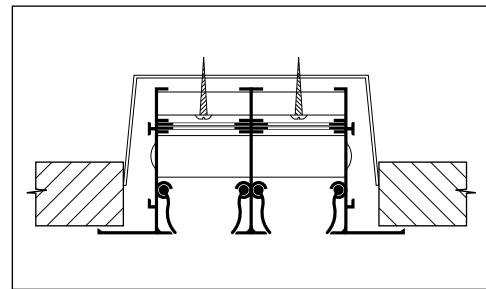

### • Fixing to the plenum box

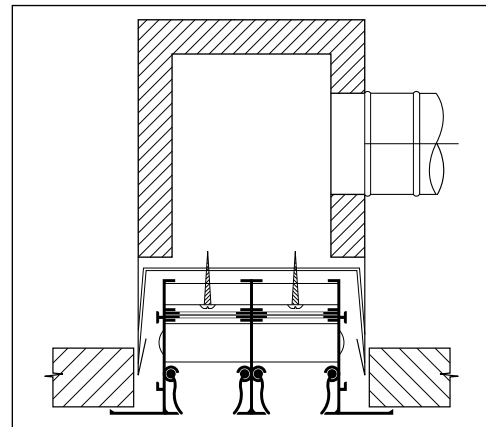



**Table 7.1 Air flow data**

Number of slots $A_x$ in m <sup>2</sup>	Air flow rate per meter length		Face Velocity m/sec	Throw in meters	$P_s$ in mm H <sub>2</sub> O	Noise Criteria (NC)
	Cfm	m <sup>3</sup> /sec				
<b>1</b>  <b>0.0092</b>	50	0.024	2.61	3.6 - 2.1 - 0.6	0.65	<15
	75	0.035	3.80	4.9 - 3.0 - 1.8	1.44	18
	100	0.047	5.11	6.1 - 4.3 - 2.7	2.55	30
	125	0.059	6.41	7.0 - 4.9 - 3.7	3.97	35
	150	0.071	7.72	7.6 - 5.8 - 4.6	4.37	38
	175	0.083	9.02	8.5 - 6.7 - 5.2	6.12	41
<b>2</b>  <b>0.018</b>	100	0.047	2.61	4.3 - 2.4 - 0.6	0.97	<15
	125	0.059	3.28	5.2 - 3.0 - 1.5	1.47	20
	150	0.071	3.94	6.1 - 3.9 - 2.1	2.12	28
	175	0.083	4.61	6.7 - 4.6 - 3.0	2.87	30
	200	0.094	5.22	7.0 - 5.2 - 4.3	3.73	33
	250	0.118	6.55	7.9 - 6.1 - 4.9	5.78	39
<b>3</b>  <b>0.028</b>	125	0.059	2.11	4.2 - 2.2 - 0.7	0.86	<15
	150	0.071	2.53	4.9 - 2.9 - 1.4	1.21	18
	200	0.094	3.36	5.5 - 3.7 - 2.4	2.17	25
	225	0.106	3.78	6.5 - 4.4 - 3.3	2.73	29
	250	0.118	4.21	7.6 - 5.3 - 4.0	3.34	34
	300	0.142	5.07	8.6 - 6.2 - 4.7	4.37	37
<b>4</b>  <b>0.0372</b>	150	0.071	1.91	4.6 - 2.7 - 1.1	0.72	<15
	200	0.094	2.53	5.4 - 3.6 - 2.0	1.39	21
	250	0.118	3.17	6.1 - 4.5 - 3.1	1.98	25
	300	0.142	3.82	6.7 - 5.2 - 3.9	2.85	30
	350	0.165	4.43	7.9 - 5.6 - 4.5	3.84	35
	400	0.189	5.08	8.8 - 6.7 - 5.2	4.51	38

- Data based on one meter length of the diffuser with damper fully opened.
- Face velocity is measured in m/sec.
- $P_s$ : Static pressure loss is in mm of H<sub>2</sub>O. Area factor in square meters.
- Throw (meters) is measured for terminal velocities of 0.25, 0.5 & 0.75 m/sec.
- NC based on a room attenuation of 10 dB.

**SUPPLY**  
**LINEAR SLOT DIFFUSER**

20mm Slot width

**air master**  
ISO 9001 CERTIFIED COMPANY**Table 7.1(cont.) Air flow data**

Number of slots $A_s$ in m <sup>2</sup>	Air flow rate per meter length		Face Velocity m/sec	Throw in meters	$P_s$ in mm H <sub>2</sub> O	Noise Criteria (NC)
	Cfm	m <sup>3</sup> /sec				
<b>5</b>  <b>0.0465</b>	250	0.118	2.54	5.8 - 4.3 - 2.7	1.43	22
	300	0.142	3.05	6.4 - 4.9 - 3.6	1.89	24
	350	0.165	3.55	6.8 - 5.3 - 3.7	2.79	29
	400	0.189	4.06	7.7 - 5.5 - 4.1	3.78	34
	450	0.213	4.58	8.5 - 5.9 - 4.7	4.25	35
	500	0.236	5.07	9.1 - 6.3 - 5.2	4.72	38
<b>6</b>  <b>0.056</b>	300	0.142	2.53	6.1 - 4.3 - 2.9	1.51	22
	350	0.165	2.95	6.6 - 5.2 - 3.9	1.64	24
	400	0.189	3.37	7.3 - 5.5 - 4.3	2.33	28
	450	0.213	3.80	7.6 - 5.8 - 4.6	3.21	31
	500	0.236	4.21	8.2 - 6.1 - 4.8	3.91	35
	600	0.283	5.05	9.2 - 6.7 - 5.3	4.78	40
<b>7</b>  <b>0.065</b>	350	0.165	2.54	6.1 - 4.3 - 2.9	1.62	22
	400	0.189	2.91	6.7 - 5.1 - 3.8	1.72	25
	450	0.213	3.28	7.0 - 5.3 - 4.0	2.33	28
	500	0.236	3.63	7.4 - 6.2 - 4.7	3.18	30
	600	0.283	4.35	8.6 - 6.7 - 5.0	4.10	36
	700	0.331	5.09	9.4 - 7.2 - 5.6	4.82	40
<b>8</b>  <b>0.076</b>	400	0.189	2.49	6.1 - 4.6 - 3.7	1.66	22
	450	0.213	2.80	6.7 - 5.1 - 3.8	1.72	25
	500	0.236	3.10	7.1 - 5.6 - 4.3	2.34	29
	600	0.283	3.72	7.6 - 6.4 - 4.7	3.24	31
	700	0.331	4.35	8.8 - 7.2 - 5.4	4.20	37
	800	0.378	4.97	9.7 - 7.8 - 5.9	4.83	40

- Data based on one meter length of the diffuser with damper fully opened.
- Face velocity is measured in m/sec.
- $P_s$ : Static pressure loss is in mm of H<sub>2</sub>O. Area factor in square meters.
- Throw (meters) is measured for terminal velocities of 0.25, 0.5 & 0.75 m/sec.
- NC based on a room attenuation of 10 dB.

**Table 7.2 Air flow data**

Number of slots $A_x$ in m <sup>2</sup>	Air flow rate per meter length		Face Velocity m/sec	Throw in meters	$P_s$ in mm H <sub>2</sub> O	Noise Criteria (NC)
	Cfm	m <sup>3</sup> /sec				
<b>1</b>  <b>0.0116</b>	75	0.035	3.02	5.3 - 3.2 - 1.9	0.78	16
	100	0.047	4.05	6.6 - 4.6 - 2.8	1.53	25
	125	0.059	5.09	7.7 - 5.3 - 3.9	2.53	29
	150	0.071	6.12	8.4 - 6.3 - 4.8	3.79	33
	175	0.083	7.15	9.4 - 7.2 - 5.5	4.05	36
	200	0.094	8.10	10.5 - 8.2 - 6.1	5.49	40
<b>2</b>  <b>0.0234</b>	125	0.059	2.52	5.6 - 3.2 - 1.6	0.94	<15
	150	0.071	3.03	6.6 - 4.1 - 2.2	1.36	17
	175	0.083	3.55	7.4 - 5.0 - 3.2	1.91	24
	200	0.094	4.02	7.7 - 5.6 - 4.5	2.13	28
	250	0.118	5.04	8.8 - 6.6 - 5.2	2.75	34
	300	0.142	6.07	10.0 - 7.9 - 6.0	3.93	39
<b>3</b>  <b>0.035</b>	150	0.071	2.03	4.9 - 2.9 - 1.2	0.83	<15
	200	0.094	2.68	5.6 - 3.6 - 2.2	1.28	17
	225	0.106	3.03	6.9 - 4.3 - 3.3	1.96	22
	250	0.118	3.37	7.7 - 5.3 - 3.9	2.13	27
	300	0.142	4.06	8.8 - 6.3 - 4.6	2.73	32
	350	0.165	4.71	10.0 - 7.4 - 5.2	3.71	36
	400	0.189	5.40	10.6 - 7.9 - 5.6	4.15	40
<b>4</b>  <b>0.048</b>	200	0.094	1.96	5.6 - 3.6 - 1.9	0.72	<15
	250	0.118	2.46	6.3 - 4.3 - 2.8	1.39	17
	300	0.142	2.96	7.0 - 4.9 - 3.6	1.92	22
	350	0.165	3.44	7.7 - 5.5 - 4.2	2.64	28
	400	0.189	3.94	8.7 - 6.6 - 4.9	2.97	32
	450	0.213	4.44	9.5 - 7.2 - 5.4	3.42	35
	500	0.236	4.92	10.0 - 7.7 - 6.0	4.18	38
	550	0.26	5.42	10.9 - 8.4 - 6.5	4.63	41

- Data based on one meter length of the diffuser with damper fully opened.
- Face velocity is measured in m/sec.
- $P_s$ : Static pressure loss is in mm of H<sub>2</sub>O. Area factor in square meters.
- Throw (meters) is measured for terminal velocities of 0.25, 0.5 & 0.75 m/sec.
- NC based on a room attenuation of 10 dB.

**SUPPLY**  
**LINEAR SLOT DIFFUSER**

25mm Slot width

**air master**  
ISO 9001 CERTIFIED COMPANY**Table 7.2(cont.) Air flow data**

Number of slots $A_x$ in m <sup>2</sup>	Air flow rate per meter length		Face Velocity m/sec	Throw in meters	$P_s$ in mm H <sub>2</sub> O	Noise Criteria (NC)
	Cfm	m <sup>3</sup> /sec				
<b>5</b>  <b>0.058</b>	300	0.142	2.45	6.6 - 4.5 - 3.5	1.42	17
	350	0.165	2.84	6.9 - 4.9 - 3.6	2.17	23
	400	0.189	3.26	7.4 - 5.2 - 3.9	2.72	26
	450	0.213	3.67	8.0 - 5.9 - 4.5	3.14	31
	500	0.236	4.07	8.8 - 6.7 - 5.2	3.68	33
	550	0.260	4.48	9.6 - 7.5 - 5.8	4.10	36
	600	0.283	4.88	10.6 - 8.4 - 6.6	4.46	38
	650	0.307	5.29	11.6 - 8.8 - 7.1	4.73	41
<b>6</b>  <b>0.071</b>	350	0.165	2.32	6.9 - 5.2 - 3.8	1.49	17
	400	0.189	2.66	7.6 - 5.6 - 4.2	1.84	21
	450	0.213	3.0	8.0 - 5.9 - 4.5	2.21	24
	500	0.236	3.32	8.8 - 6.3 - 4.9	2.94	28
	600	0.283	3.98	9.2 - 6.8 - 5.2	3.69	32
	700	0.331	4.66	10.7 - 8.4 - 6.5	4.26	37
	800	0.378	5.32	12.0 - 9.1 - 7.4	5.13	41
<b>7</b>  <b>0082</b>	400	0.189	2.30	7.0 - 5.3 - 4.0	1.51	17
	450	0.213	2.60	7.8 - 5.9 - 4.5	1.93	22
	500	0.236	2.88	7.9 - 6.2 - 4.7	2.23	24
	600	0.283	3.45	9.0 - 6.6 - 5.3	3.14	29
	700	0.331	4.04	9.6 - 7.1 - 5.6	3.97	34
	800	0.378	4.61	11.0 - 8.9 - 7.0	4.47	38
	900	0.425	5.18	12.2 - 9.4 - 7.5	5.34	42
<b>8</b>  <b>0.094</b>	500	0.236	2.51	7.2 - 5.6 - 4.2	1.82	18
	600	0.283	3.01	8.5 - 6.3 - 5.0	3.05	28
	700	0.331	3.52	9.3 - 6.8 - 5.5	3.18	31
	800	0.378	4.02	9.8 - 7.4 - 6.0	4.12	35
	900	0.425	4.52	11.3 - 9.2 - 7.3	4.63	39
	1000	0.472	5.02	12.5 - 9.6 - 7.8	5.34	43

- Data based on one meter length of the diffuser with damper fully opened.
- Face velocity is measured in m/sec.
- $P_s$ : Static pressure loss is in mm of H<sub>2</sub>O. Area factor in square meters.
- Throw (meters) is measured for terminal velocities of 0.25, 0.5 & 0.75 m/sec.
- NC based on a room attenuation of 10 dB.

**Table 7.3 Air flow data**

Number of slots $A_x$ in m <sup>2</sup>	Air flow rate per meter length		Face Velocity m/sec	Throw in meters	$P_s$ in mm H <sub>2</sub> O	Noise Criteria (NC)
	Cfm	m <sup>3</sup> /sec				
<b>1</b>  <b>0.0072</b>	30	0.014	1.94	2.5 - 1.5 - 0.4	0.51	<15
	50	0.024	3.33	4.1 - 2.5 - 1.4	1.34	18
	75	0.035	4.86	5.6 - 3.8 - 2.3	2.62	29
	100	0.047	6.53	6.8 - 4.7 - 3.3	4.41	36
	125	0.059	8.19	7.4 - 5.0 - 3.8	5.10	40
	150	0.071	9.86	8.1 - 5.8 - 4.4	7.42	43
<b>2</b>  <b>0.014</b>	50	0.024	1.71	3.0 - 1.6 - 0.6	0.65	<15
	75	0.035	2.50	3.7 - 2.0 - 0.9	1.19	17
	100	0.047	3.36	4.3 - 2.5 - 1.3	1.95	21
	125	0.059	4.21	5.3 - 3.7 - 1.9	2.83	29
	150	0.071	5.07	6.2 - 4.4 - 2.8	3.95	33
	200	0.094	6.71	7.3 - 4.9 - 3.5	6.57	41
<b>3</b>  <b>0.021</b>	100	0.047	2.24	3.5 - 1.9 - 0.8	0.96	17
	125	0.059	2.81	3.9 - 2.2 - 1.1	1.42	21
	150	0.071	3.38	4.9 - 2.8 - 1.7	2.36	25
	175	0.083	3.95	5.3 - 3.4 - 2.1	3.11	30
	200	0.094	4.48	5.9 - 3.9 - 2.4	3.91	36
	250	0.118	5.62	6.9 - 5.2 - 3.3	5.38	39
<b>4</b>  <b>0.028</b>	125	0.059	2.11	3.6 - 2.0 - 0.9	0.84	17
	150	0.071	2.53	3.9 - 2.3 - 1.3	1.49	22
	175	0.083	2.96	4.4 - 3.1 - 1.9	2.0	25
	200	0.094	3.36	5.2 - 3.4 - 2.2	2.73	29
	250	0.120	4.28	5.9 - 4.1 - 2.7	4.03	34
	300	0.142	5.07	6.4 - 4.9 - 3.2	5.0	38

- Data based on one meter length of the diffuser with damper fully opened.
- Face velocity is measured in m/sec.
- $P_s$ : Static pressure loss is in mm of H<sub>2</sub>O. Area factor in square meters.
- Throw (meters) is measured for terminal velocities of 0.25, 0.5 & 0.75 m/sec.
- NC based on a room attenuation of 10 dB.

**SUPPLY**  
**LINEAR SLOT DIFFUSER**

16mm Slot width

**air master**  
ISO 9001 CERTIFIED COMPANY**Table 7.3(cont.) Air flow data**

Number of slots $A_x$ in $m^2$	Air flow rate per meter length		Face Velocity m/sec	Throw in meters	$P_s$ in $mm H_2O$	Noise Criteria (NC)
	Cfm	$m^3/sec$				
<b>5</b>	150	0.071	1.97	3.7 - 2.1 - 1.0	1.16	16
	200	0.094	2.61	4.1 - 2.5 - 1.5	1.71	23
	250	0.118	3.28	5.2 - 3.4 - 2.2	2.73	29
<b>0.036</b>	300	0.142	3.94	6.0 - 4.2 - 2.8	3.96	32
	350	0.165	4.58	6.4 - 4.9 - 3.2	4.63	35
	400	0.189	5.25	7.3 - 5.5 - 3.7	5.38	39
<b>6</b>	200	0.094	2.19	3.9 - 2.4 - 1.3	1.37	18
	250	0.118	2.74	4.7 - 2.8 - 1.7	1.61	24
	300	0.142	3.30	5.6 - 3.6 - 2.5	2.46	30
<b>0.043</b>	350	0.165	3.84	6.3 - 4.4 - 3.0	3.53	33
	400	0.189	4.39	6.7 - 5.2 - 3.5	4.48	36
	500	0.236	5.49	7.9 - 5.6 - 4.1	5.77	41
<b>7</b>	250	0.118	2.41	4.2 - 2.5 - 1.4	1.61	20
	300	0.142	2.90	4.9 - 3.1 - 1.9	1.82	25
	350	0.165	3.37	5.9 - 3.8 - 2.6	2.58	29
<b>0.049</b>	400	0.189	3.86	6.5 - 4.7 - 3.2	3.68	32
	500	0.236	4.82	7.1 - 5.3 - 3	5.0	37
	600	0.283	5.77	8.3 - 5.9 - 4.3	6.06	42
<b>8</b>	350	0.165	2.89	5.1 - 3.2 - 2.2	2.02	24
	400	0.189	3.31	6.0 - 3.9 - 2.7	2.15	30
	450	0.213	3.74	6.6 - 4.8 - 3.3	3.02	32
<b>0.057</b>	500	0.236	4.14	7.0 - 5.2 - 3.6	3.89	35
	600	0.283	4.96	8.3 - 5.6 - 4.2	5.16	39
	700	0.331	5.81	8.7 - 6.1 - 4.5	6.27	42

- Data based on one meter length of the diffuser with damper fully opened.
- Face velocity is measured in m/sec.
- $P_s$ : Static pressure loss is in mm of  $H_2O$ . Area factor in square meters.
- Throw (meters) is measured for terminal velocities of 0.25, 0.5 & 0.75 m/sec.
- NC based on a room attenuation of 10 dB.

**Table 7.4 Air flow data**

No. of slots							
1	CFM/m	100	150	200	250	300	350
	M <sup>3</sup> /sec/m	0.047	0.071	0.094	0.118	0.142	0.165
	Neg P <sub>s</sub>	0.61	1.37	2.41	3.81	5.46	7.37
	NC	<15	19	28	36	42	48
2	CFM m	250	300	350	400	450	500
	M <sup>3</sup> /sec/m	0.118	0.142	0.165	0.189	0.212	0.236
	Neg P <sub>s</sub>	1.02	1.47	2.03	2.62	3.30	4.06
	NC	17	22	27	32	36	40
3	CFM/m	350	400	450	500	600	700
	M <sup>3</sup> /sec/m	0.165	0.189	0.212	0.236	0.283	0.331
	Neg P <sub>s</sub>	1.04	1.35	1.68	2.08	2.97	4.01
	NC	17	22	25	30	34	40
4	CFM/m	400	500	600	700	800	900
	M <sup>3</sup> /sec/m	0.189	0.236	0.283	0.331	0.378	0.425
	Ne P <sub>s</sub>	0.76	1.19	1.73	2.36	3.25	4.06
	NC	15	21	26	30	35	40
5	CFM/m	500	600	700	800	1000	1200
	M <sup>3</sup> /sec/m	0.236	0.283	0.331	0.378	0.472	0.567
	Neg P <sub>s</sub>	0.76	1.12	1.52	1.96	3.05	4.37
	NC	15	22	27	30	35	42
6	CFM/m	600	700	800	1000	1200	1400
	M <sup>3</sup> /sec/m	0.283	0.331	0.378	0.472	0.567	0.66
	Neg P <sub>s</sub>	0.83	1.08	1.78	2.18	3.53	4.75
	NC	17	24	29	31	37	43
7	CFM/m	700	800	1000	1200	1400	1600
	M <sup>3</sup> /sec/m	0.331	0.378	0.472	0.567	0.66	0.76
	Neg P <sub>s</sub>	0.93	1.13	1.83	2.36	3.66	4.75
	NC	18	25	30	33	38	43
8	CFM/m	800	900	1100	1300	1500	1700
	M <sup>3</sup> /sec/m	0.378	0.425	0.52	0.61	0.71	0.8
	Neg P <sub>s</sub>	1.02	1.13	96	2.45	3.87	4.93
	NC	18	25	32	35	40	45

- Data based on one meter length of the diffuser.
- NC based on a room attenuation of 10 dB.
- P<sub>s</sub>: Static pressure loss is in mm of water.

**RETURN**  
**LINEAR SLOT DIFFUSER**

25mm Slot width

**air master**  
ISO 9001 CERTIFIED COMPANY**Table 7.5 Air flow data**

No. of slots							
1	CFM/m	100	150	200	250	300	350
	M <sup>3</sup> /sec/m	0.047	0.071	0.094	0.118	0.142	0.165
	Neg P <sub>s</sub>	0.51	1.13	1.98	3.09	4.4	5.89
	NC	<15	18	26	33	38	45
2	CFM/m	250	300	350	400	450	500
	M <sup>3</sup> /sec/m	0.118	0.142	0.165	0.189	0.213	0.236
	Neg P <sub>s</sub>	0.85	1.22	1.67	2.13	2.66	3.25
	NC	<15	21	25	29	33	37
3	CFM/m	350	400	450	500	600	700
	M <sup>3</sup> /sec/m	0.165	0.189	0.213	0.236	0.283	0.331
	Neg P <sub>s</sub>	0.87	1.11	1.37	1.69	2.39	3.21
	NC	16	21	23	28	31	37
4	CFM/m	400	500	600	700	800	900
	M <sup>3</sup> /sec/m	0.189	0.236	0.283	0.331	0.378	0.425
	Neg P <sub>s</sub>	0.64	0.99	1.42	1.92	2.62	3.25
	NC	<15	20	24	28	32	37
5	CFM/m	500	600	700	800	1000	1200
	M <sup>3</sup> /sec/m	0.236	0.283	0.331	0.378	0.472	0.567
	Neg P <sub>s</sub>	0.64	0.92	1.25	1.59	2.46	3.49
	NC	<15	21	25	27	32	39
6	CFM/m	600	700	800	1000	1200	1400
	M <sup>3</sup> /sec/m	0.283	0.331	0.378	0.472	0.567	0.66
	Neg P <sub>s</sub>	0.67	0.83	1.39	1.77	3.85	3.8
	NC	16	23	27	28	34	40
7	CFM/m	700	800	1000	1200	1400	1600
	M <sup>3</sup> /sec/m	0.331	0.378	0.472	0.567	0.66	0.76
	Neg P <sub>s</sub>	0.75	0.91	1.48	1.92	2.95	3.8
	NC	17	24	28	29	35	40
8	CFM/m	800	900	1100	1300	1500	1700
	M <sup>3</sup> /sec/m	0.378	0.425	0.52	0.61	0.71	0.8
	Neg P <sub>s</sub>	0.83	0.91	1.56	1.99	3.12	3.94
	NC	17	24	30	32	37	42

- Data based on one meter length of the diffuser.
- NC based on a room attenuation of 10 dB.
- P<sub>s</sub>: Static pressure loss is in mm of water.



**Table 7.6 Air flow data**

No. of slots							
1	CFM/m	100	150	200	250	300	350
	M <sup>3</sup> /sec/m	0.047	0.071	0.094	0.118	0.142	0.165
	Neg P <sub>s</sub>	0.7	1.59	2.82	4.49	6.49	8.84
	NC	17	21	30	38	45	52
2	CFM/m	250	300	350	400	450	500
	M <sup>3</sup> /sec/m	0.118	0.142	0.165	0.189	0.213	0.236
	Neg P <sub>s</sub>	1.17	1.71	2.38	3.09	3.93	4.88
	NC	20	26	31	37	42	46
3	CFM/m	350	400	450	500	600	700
	M <sup>3</sup> /sec/m	0.165	0.189	0.213	0.236	0.283	0.331
	Neg P <sub>s</sub>	1.19	1.56	1.96	2.42	3.54	4.82
	NC	20	26	29	34	40	46
4	CFM/m	400	500	600	700	800	900
	M <sup>3</sup> /sec/m	0.189	0.236	0.283	0.331	0.378	0.425
	Neg P <sub>s</sub>	0.88	1.38	2.02	2.78	3.87	4.88
	NC	17	25	30	35	41	47
5	CFM/m	500	600	700	800	1000	1200
	M <sup>3</sup> /sec/m	0.236	0.283	0.331	0.378	0.472	0.567
	Neg P <sub>s</sub>	0.88	1.29	1.78	2.31	3.63	5.24
	NC	17	26	29	35	41	48
6	CFM/m	600	700	800	1000	1200	1400
	M <sup>3</sup> /sec/m	0.283	0.331	0.378	0.472	0.567	0.66
	Neg P <sub>s</sub>	0.96	1.25	2.08	2.57	4.20	5.7
	NC	19	28	34	37	40	49
7	CFM/m	700	800	1000	1200	1400	1600
	M <sup>3</sup> /sec/m	0.331	0.378	0.472	0.567	0.66	0.76
	Neg P <sub>s</sub>	1.07	1.38	2.14	2.78	4.36	5.7
	NC	20	28	33	39	43	50
8	CFM/m	800	900	1100	1300	1500	1700
	M <sup>3</sup> /sec/m	0.378	0.425	0.52	0.61	0.71	0.8
	Neg P <sub>s</sub>	1.17	1.31	2.29	2.89	4.61	5.9
	NC	22	31	37	40	45	50

- Data based on one meter length of the diffuser.
- NC based on a room attenuation of 10 dB.
- P<sub>s</sub>: Static pressure loss is in mm of water.
- Above data is tested & certified by ETL



### CONSTRUCTION:

**Frame & Blades:** High quality extruded aluminium profiles.

**Slot width:** 19 mm as standard.

**Number of slots available:** 1,2,3,4,5,6,7,8.

**Length:** Up to 5.8 meters available in a single piece.

**Optional accessories:** Plenum box either un lined, internally insulated or externally insulated.

### Description:

- Frame and deflection blades are made of high quality extruded aluminium profiled construction with the advantages of corrosion resistance and rigidity.
- This high capacity linear flow air diffuser is designed to achieve best possible horizontal air pattern with excellent static pressure, throw and sound characteristics.
- This totally removable pattern control device allow access for installation and balancing with option of choosing the black/white extruded aluminium pattern control device which allows 180° pattern adjustment and volume control in the same unit (without using damper).
- Positive alignment of adjacent sections can be made by using alignment strips.
- Foam gasket is sealed around the back of the frame as option to avoid air leakage.

### Standard finishes:

- Natural anodized aluminium finish.
- Powder coated colour finish as per RAL colour code.
- Flexibility of finish available as option.

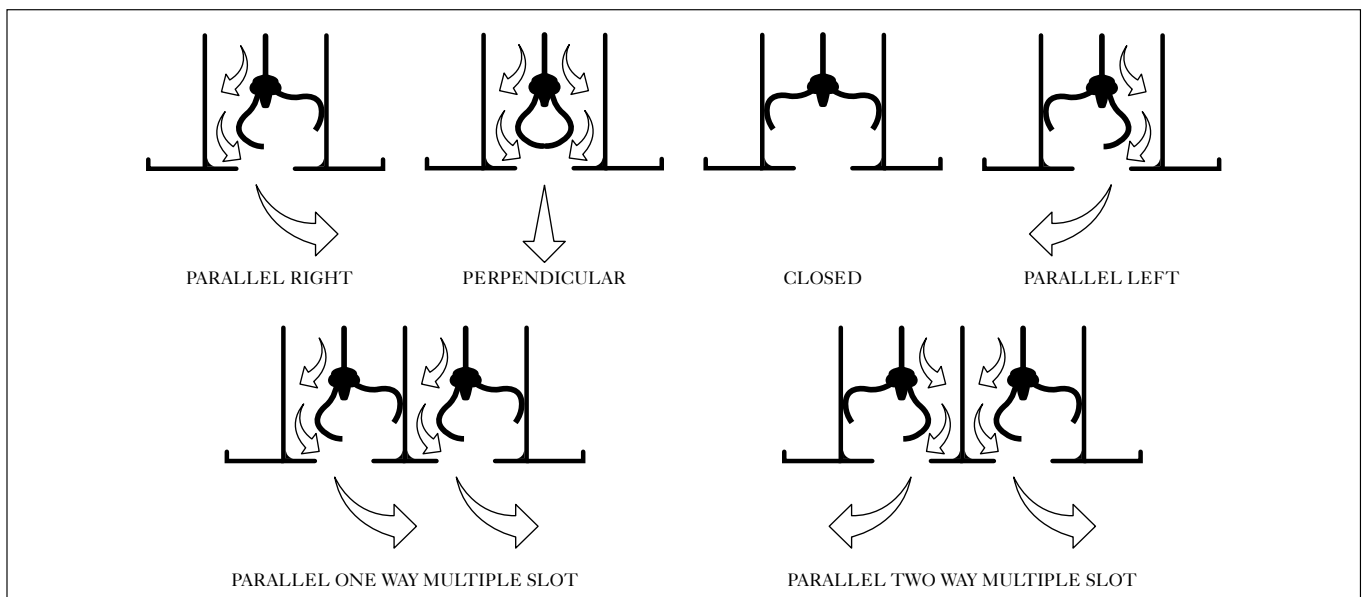
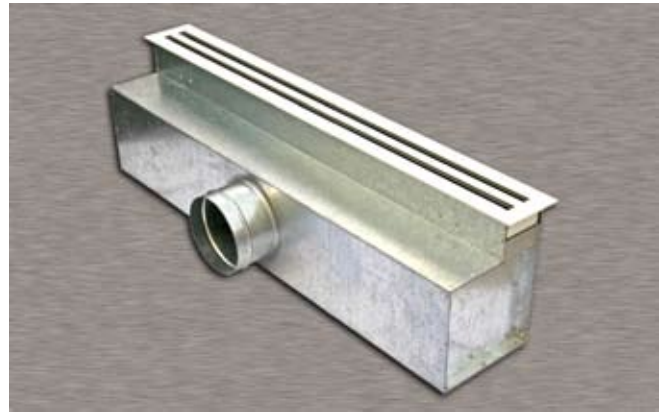

# LINEAR SLOT DIFFUSER

model: **ASMLD**

16mm Slot width

## Air flow data

<b>1 slot</b>	Airflow Cfm	80	88	99	109	119	130	143	155	168
	M <sup>3</sup> /sec	0.038	0.042	0.047	0.051	0.056	0.061	0.067	0.073	0.079
	P <sub>s</sub> in mm H <sub>2</sub> O	1.14	1.40	1.78	2.16	2.54	3.05	3.68	4.32	5.08
	Throw in m	2.1-4.0-5.5	2.4-4.3-5.8	3.0-4.6-6.1	3.4-4.9-6.4	3.7-5.2-6.7	4.0-5.5-7.0	4.3-5.8-7.3	4.6-5.8-7.3	4.6-6.1-7.6
	NC	<15	<15	<15	17	20	22	25	29	32

<b>2 slot</b>	Airflow Cfm	132	146	166	182	196	215	237	256	278
	M <sup>3</sup> /sec	0.062	0.069	0.078	0.085	0.092	0.101	0.112	0.121	0.131
	P <sub>s</sub> in mm H <sub>2</sub> O	1.14	1.40	1.78	2.16	2.54	3.05	3.68	4.32	5.08
	Throw in m	1.8-3.6-5.5	2.1-4.0-5.8	2.7-4.6-6.4	3.0-4.9-6.7	3.5-4.9-7.0	3.7-5.2-7.0	3.7-5.2-7.3	4.0-5.5-7.3	4.0-5.8-7.6
	NC	<15	<15	19	22	24	26	29	31	34

<b>3 slot</b>	Airflow Cfm	178	196	223	244	266	290	320	345	375
	M <sup>3</sup> /sec	0.084	0.092	0.105	0.115	0.125	0.137	0.151	0.163	0.177
	P <sub>s</sub> in mm H <sub>2</sub> O	1.14	1.40	1.78	2.16	2.54	3.05	3.68	4.32	5.08
	Throw in m	1.2-2.7-4.3	1.5-3.0-4.6	2.1-3.7-5.2	2.4-4.3-5.8	2.7-4.6-6.4	3.0-4.9-6.7	3.3-5.2-7.0	3.7-5.5-7.3	4.0-5.8-7.6
	NC	15	17	21	23	26	28	31	33	36

<b>4 slot</b>	Airflow Cfm	232	257	290	320	346	380	418	452	490
	M <sup>3</sup> /sec	0.109	0.121	0.137	0.151	0.163	0.179	0.197	0.213	0.231
	P <sub>s</sub> in mm H <sub>2</sub> O	1.14	1.40	1.78	2.16	2.54	3.05	3.68	4.32	5.08
	Throw in m	1.2-2.4-4.0	1.5-2.7-4.3	1.8-3.3-4.9	2.1-3.7-5.5	2.4-4.0-6.1	3.0-4.6-6.7	3.3-4.9-7.0	3.7-5.2-7.0	4.0-5.5-7.6
	NC	16	19	23	25	28	30	33	36	40

<b>5 slot</b>	Airflow Cfm	306	338	382	422	456	500	550	595	645
	M <sup>3</sup> /sec	0.144	0.159	0.180	0.199	0.215	0.236	0.259	0.281	0.304
	P <sub>s</sub> in mm H <sub>2</sub> O	1.14	1.40	1.78	2.16	2.54	3.05	3.68	4.32	5.08
	Throw in m	1.2-2.1-4.0	1.5-2.4-4.3	1.8-2.7-4.9	2.1-3.0-5.2	2.7-3.6-5.8	3.0-4.3-6.4	3.3-4.9-6.7	3.7-5.2-7.0	4.0-5.5-7.3
	NC	18	21	25	27	30	33	36	40	44

<b>6 slot</b>	Airflow Cfm	380	420	473	522	565	620	680	740	800
	M <sup>3</sup> /sec	0.179	0.198	0.223	0.246	0.267	0.293	0.321	0.349	0.377
	P <sub>s</sub> in mm H <sub>2</sub> O	1.14	1.40	1.78	2.16	2.54	3.05	3.68	4.32	5.08
	Throw in m	1.2-2.1-4.0	1.5-2.4-4.6	1.8-2.7-4.9	2.1-3.4-5.5	2.7-4.0-5.8	2.7-4.6-6.4	3.0-4.6-6.7	3.3-4.9-7.0	3.7-5.2-7.0
	NC	18	21	25	28	31	35	38	41	45



### Air flow data (cont.)

<b>7 slot</b>	Airflow Cfm	460	510	570	630	685	750	825	890	970
	M <sup>3</sup> /sec	0.217	0.241	0.269	0.297	0.323	0.354	0.389	0.420	0.458
	P <sub>s</sub> in mm H <sub>2</sub> O	1.14	1.40	1.78	2.16	2.54	3.05	3.68	4.32	5.08
	Throw in m	1.2-2.1-4.3	1.5-2.4-4.6	1.8-2.7-4.9	2.1-3.4-5.2	2.7-4.0-5.8	2.7-4.3-6.1	3.0-4.6-6.4	3.3-4.9-6.7	3.7-5.2-7.0
	NC	19	22	26	29	32	36	39	42	46

<b>8 slot</b>	Airflow Cfm	540	595	675	740	805	880	970	1050	1140
	M <sup>3</sup> /sec	0.255	0.281	0.318	0.349	0.380	0.415	0.458	0.495	0.538
	P <sub>s</sub> in mm H <sub>2</sub> O	1.14	1.40	1.78	2.16	2.54	3.05	3.68	4.32	5.08
	Throw in m	1.2-2.1-4.3	1.5-2.4-4.6	1.8-2.7-4.9	2.1-3.4-5.2	2.4-4.0-5.8	2.7-4.3-6.1	3.0-4.6-6.4	3.3-4.9-6.7	3.7-5.2-7.0
	NC	20	23	27	30	33	36	39	42	47

- Neck velocity is measured in m/sec.
- P<sub>s</sub>: Static pressure loss across the diffuser is in mm of H<sub>2</sub>O.
- Throw (meters) is measured for terminal velocities of 0.75, 0.5 & 0.25 m/sec.
- Noise criteria (NC) based on a room attenuation of 10 dB.

Seef Mall Food Court, Bahrain



## PLENUM SLOT DIFFUSER

model: **ASMPD**

### CONSTRUCTION:

**Frame & Blades:** 22 or 20 gauge galvanized steel sheet.

**Blades:** High quality extruded aluminium profile.

**Slot width:** 19mm as standard.

**Number of slots available:** 1, 2, 3, 4.

**Length:** 600mm, 900mm & 1200mm standard.

**Spigots:** Circular spigots of 50mm length as standard.

**Optional accessories:** Internal insulation, volume control damper.

### Description:

- Frame fabricated from 22 or 20 gauge galvanized steel sheet and deflection blades are made of high quality extruded aluminium profiles.
- This high capacity plenum slot diffuser is designed to achieve best possible horizontal air pattern with excellent static pressure, throw and sound characteristics.
- This totally removable pattern control device allow access for installation and balancing with option of choosing the black/white extruded aluminium pattern control device which allows 180° pattern adjustment and volume control in the same unit (without using damper).
- Circular spigots of required diameter and standard length of 50mm would be fixed to the plenum box.
- Volume control dampers can be fixed to the spigots on request.

### Standard finishes:

- Deflection blades can be of natural anodized aluminium finish or powder coated color finish as per RAL color codes.
- Flexibility of finish available.

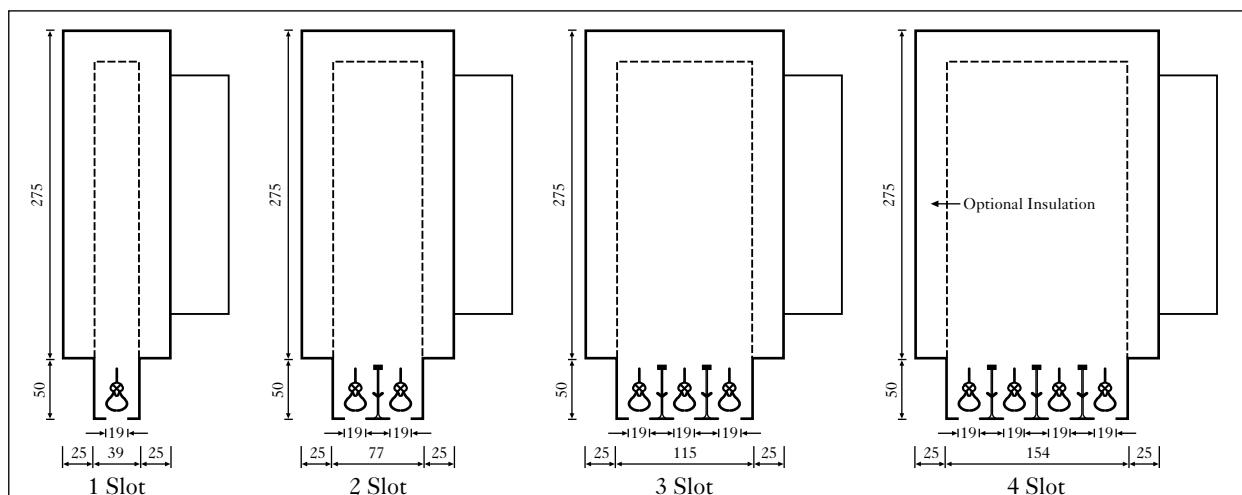
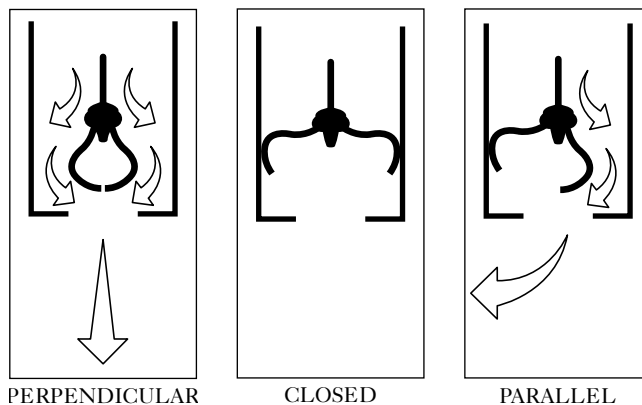



### Air flow data

<b>1 slot</b>	Airflow Cfm	80	88	99	109	119	130	143	155	168
	M <sup>3</sup> /sec	0.038	0.042	0.047	0.051	0.056	0.061	0.067	0.073	0.079
	P <sub>s</sub> in mm H <sub>2</sub> O	1.14	1.40	1.78	2.16	2.54	3.05	3.68	4.32	5.08
	Throw in m	2.1-4.0-5.5	2.4-4.3-5.8	3.0-4.6-6.1	3.4-4.9-6.4	3.7-5.2-6.7	4.0-5.5-7.0	4.3-5.8-7.3	4.6-5.8-7.3	4.6-6.1-7.6
	NC	<15	<15	<15	17	20	22	25	29	32

<b>2 slot</b>	Airflow Cfm	132	146	166	182	196	215	237	256	278
	M <sup>3</sup> /sec	0.062	0.069	0.078	0.085	0.092	0.101	0.112	0.121	0.131
	P <sub>s</sub> in mm H <sub>2</sub> O	1.14	1.40	1.78	2.16	2.54	3.05	3.68	4.32	5.08
	Throw in m	1.8-3.6-5.5	2.1-4.0-5.8	2.7-4.6-6.4	3.0-4.9-6.7	3.5-4.9-7.0	3.7-5.2-7.0	3.7-5.2-7.3	4.0-5.5-7.3	4.0-5.8-7.6
	NC	<15	<15	19	22	24	26	29	31	34

<b>3 slot</b>	Airflow Cfm	178	196	223	244	266	290	320	345	375
	M <sup>3</sup> /sec	0.084	0.092	0.105	0.115	0.125	0.137	0.151	0.163	0.177
	P <sub>s</sub> in mm H <sub>2</sub> O	1.14	1.40	1.78	2.16	2.54	3.05	3.68	4.32	5.08
	Throw in m	1.2-2.7-4.3	1.5-3.0-4.6	2.1-3.7-5.2	2.4-4.3-5.8	2.7-4.6-6.4	3.0-4.9-6.7	3.3-5.2-7.0	3.7-5.5-7.3	4.0-5.8-7.6
	NC	15	17	21	23	26	28	31	33	36

<b>4 slot</b>	Airflow Cfm	232	257	290	320	346	380	418	452	490
	M <sup>3</sup> /sec	0.109	0.121	0.137	0.151	0.163	0.179	0.197	0.213	0.231
	P <sub>s</sub> in mm H <sub>2</sub> O	1.14	1.40	1.78	2.16	2.54	3.05	3.68	4.32	5.08
	Throw in m	1.2-2.4-4.0	1.5-2.7-4.3	1.8-3.3-4.9	2.1-3.7-5.5	2.4-4.0-6.1	3.0-4.6-6.7	3.3-4.9-7.0	3.7-5.2-7.0	4.0-5.5-7.6
	NC	16	19	23	25	28	30	33	36	40

- Neck velocity is measured in m/sec.
- P<sub>s</sub>: Static pressure loss across the diffuser s in mm of H<sub>2</sub>O.
- Throw (meters) is measured for terminal velocities of 0.75, 0.5 & 0.25 m/sec.
- Noise criteria (NC) based on a room attenuation of 10 dB.

## Product summary:

Model Number	Product Description	Remarks
ASLD	Supply linear slot diffuser	
ARLD	Return linear slot diffuser	
ASLD (C)	SLD curved	
ARLD (C)	RLD curved	
ASMLD	Slot diffuser – 19mm slot	With Removable pattern control device
ASMPD	Plenum Slot diffuser – 19 mm slot	With Removable pattern control device

## Product order checklist:

- Model: Please refer product summary above
- Number of slots
- Slot width
- End flange/cap details (open end, one side flange/end cap or both side flange/caps)
- Quantity
- Colour (RAL 9010, 9016, Anodised aluminium finish or other RAL colours)
- Drawing or template necessary for curved bar grilles.

*Etisalat building, Dubai.*





**air master**  
ISO 9001 CERTIFIED COMPANY

**AIR MASTER EQUIPMENTS EMIRATES LLC.**

Post Box - 3180, Ajman, U.A.E.

Tel: +971 6 7436900, 7439600 Fax: +971 6 7436700

E-mail: [airmastr@eim.ae](mailto:airmastr@eim.ae), [sales@airmaster.ae](mailto:sales@airmaster.ae)